

PRODUCT INFORMATION PACKET



Model No: 121465.00

Catalog No: 121465.00

General Purpose Motor, 2 HP, 1 Ph, 60 Hz, 115/208-230 V, 1800 RPM, 145TC Frame, TEFC



Regal and Leeson are trademarks of Regal Rexnord Corporation or one of its affiliated companies.

©2022 Regal Rexnord Corporation, All Rights Reserved. MC017097E





Nameplate Specifications

Output HP	2 Hp	Output KW	1.5 kW
Frequency	60 Hz	Voltage	115/208-230 V
Current	18.4/9.2 A	Speed	1740 rpm
Service Factor	1	Phase	1
Efficiency	82 %	Power Factor	86
Duty	Continuous	Insulation Class	B
Design Code	L	KVA Code	H
Frame	145TC	Enclosure	Totally Enclosed Fan Cooled
Thermal Protection	Manual	Ambient Temperature	40 °C
Drive End Bearing Size	6205	Opp Drive End Bearing Size	6203
UL	Recognized (Not Protector)	CSA	Y
CE	N	IP Code	43
Number of Speeds	1		

Technical Specifications

Electrical Type	Capacitor Start Capacitor Run	Starting Method	Across The Line
Poles	4	Rotation	Selective Counterclockwise
Resistance Main	0 Ohms	Mounting	Rigid Base
Motor Orientation	Horizontal	Drive End Bearing	Ball
Opp Drive End Bearing	Ball	Frame Material	Rolled Steel
Shaft Type	T	Overall Length	13.93 in
Frame Length	8.00 in	Shaft Diameter	0.875 in
Shaft Extension	2.25 in	Assembly/Box Mounting	F1 ONLY
Outline Drawing	028905-800B	Connection Drawing	005053.02

RBC PROPRIETARY AND CONFIDENTIAL INFORMATION
 This document is the property of REGAL BELOIT CORPORATION ("RBC") including its subsidiaries and divisions and contains proprietary information of RBC. This document is loaned on the express condition that neither it nor the information contained therein shall be disclosed to others without the express written consent of RBC, and that the information shall be used by the recipient only as approved expressly by RBC. This document shall be returned to RBC upon its request. This document may be subject to certain restrictions under U.S. export control laws and regulations.

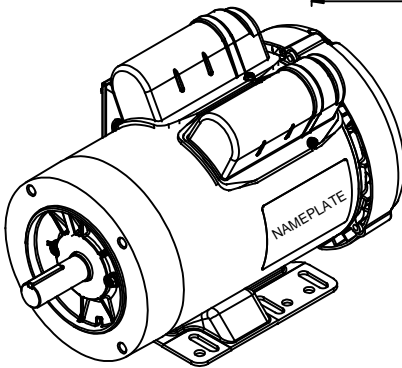
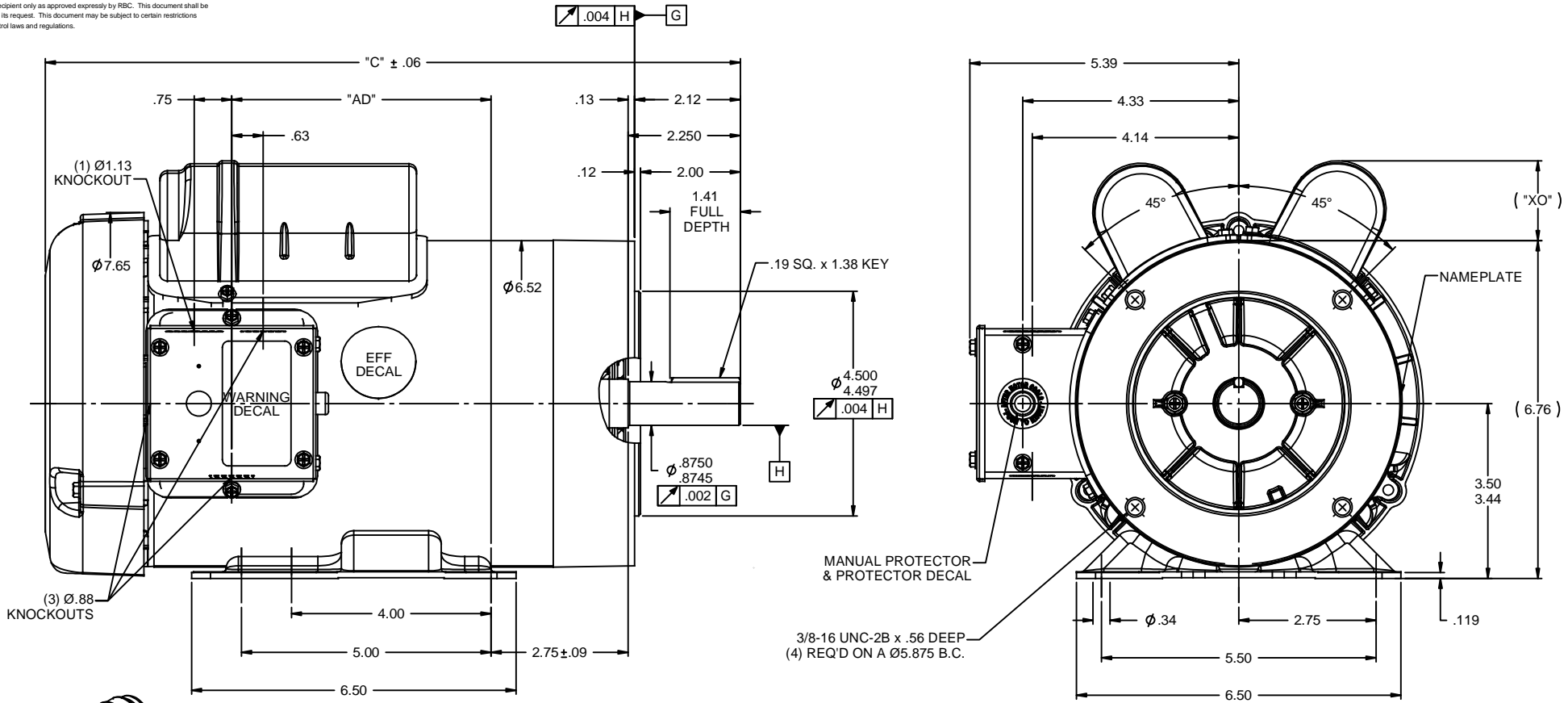

DASH NO.	"C"	"AD"	CAP DASH	"XO"
700	12.93	4.19	A	1.15
750	13.43	4.69	B	1.60
800	13.93	5.19	C	1.60
850	14.43	5.69	C	1.82

NOTE:
1) GASKETS THROUGHOUT

REVISION		BY & DATE	CHK	ANG	±1/2°	FINISH	PAGE OF	
THIRD ANGLE PROJECTION			RFP	11/24/08	PREV		SIZE	DRAWING NO
			NETWORK FILE NAME				B	028905

TOLERANCES UNLESS SPECIFIED		LEESON ELECTRIC MOTORS GEARMOTORS AND DRIVES		DRAWN
DEC	INCHES			GRB 11/24/08
x	±.1			CHK DJ 11/24/08
.xx	±.03	TITLE OUTLINE - 145TC FRAME		APPR DJ 11/24/08
.xxx	±.005	TEFC - RIGID "C" FACE		SCALE 1:2
.xxx	±.0005	MATL		REF OL121465
				FMF 121465.00

VIEW FROM OUTSIDE OF MOTOR AT SWITCH END.

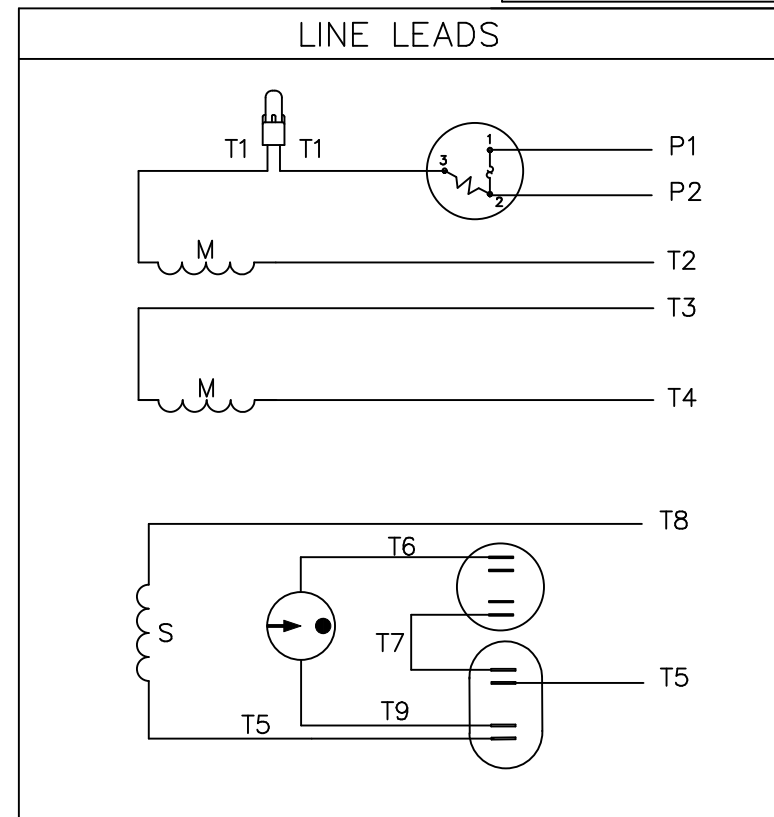
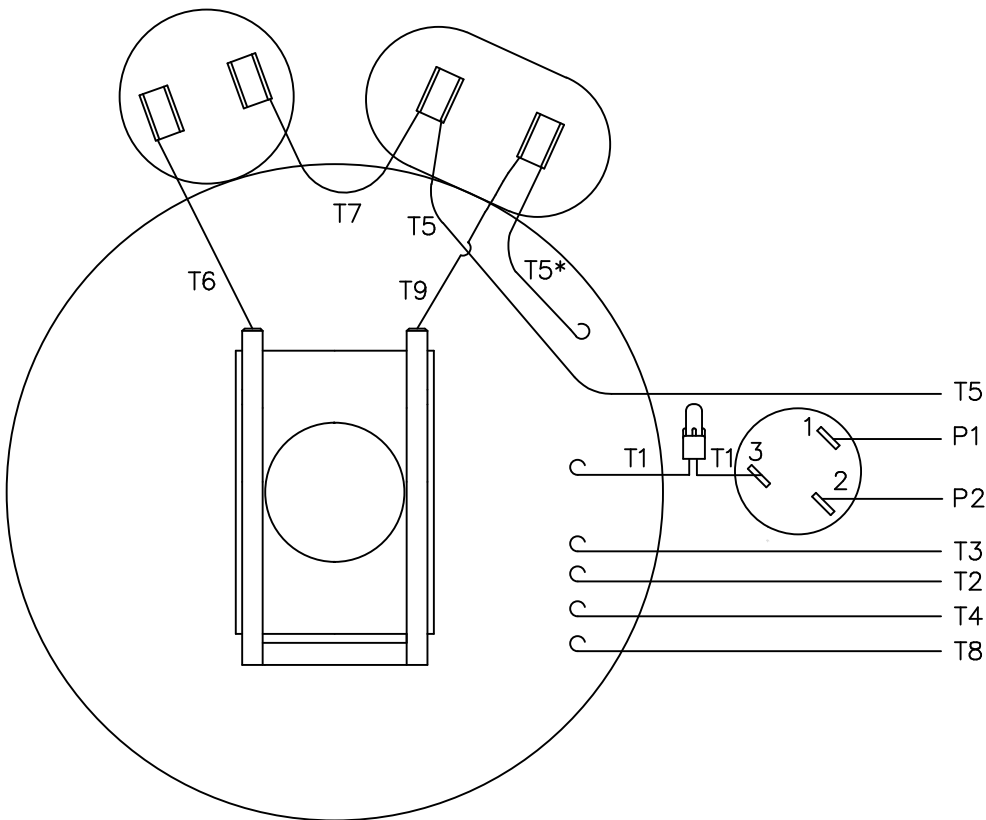

	ROTATION FACING LEAD END	L1	L2	JOIN	INSULATE SEPARATELY
HIGH VOLT	C.C.W.	P1	T4 T5	T2,T3 T8	P2
	C.W.	P1	T4 T8	T2,T3 T5	P2
LOW VOLT	C.C.W.	P1	T2,T4 T5	P2,T3 T8	-----
	C.W.	P1	T2,T4 T8	P2,T3 T5	-----

* THIS LEAD MAY BE WHITE

		TOLERANCES UNLESS SPECIFIED	
		DEC.	INCHES
		.X	±.1
		.XX	±.01
04	ADDED "*" TO T5	RLW 7/22/02	.XXX ±.005
03	REDRAWN ON CAD	DBT 05/27/97	.XXXX ±.0005
NO.	REVISION	BY & DATE	CHK ANG ±1/2"

REGAL-BELOIT *Motor Technologies Group*

TITLE: EXTERNAL WIRING DIAGRAM
TYPE "K" W/PROTECTOR

DRAWN	ADH 06/16/76
CHK	WRK 06/30/76
APPD	
SCALE	1=1
REF	
FMF	6K17FB8A
PREV	

RFP	CAD FILE	00505302	SIZE	DRAWING NO.	REV.
DIST			A	005053-02	04



**1051 CHEYENNE AVE.
GRAFTON, WI 53024
PH. 262-377-8810**

CERTIFICATION DATA SHEET

CATALOG #: 121465.00

CONN. DIAGRAM: 005053.02

OUTLINE: 028905-800B

MOUNTING: F1 ONLY

WINDING #: K634271 FR 3 A

TYPICAL MOTOR PERFORMANCE DATA

HP	kW	SYNC. RPM	F.L. RPM	FRAME	ENCLOSURE	KVA CODE	DESIGN
2	1.49	1800	1740	145TC	TEFC	H	L

PH	Hz	VOLTS	AMPS	START TYPE	DUTY	INSL	S.F.	AMB°C
1	60	115/208-230	18.4/9.2	ACROSS THE LINE	CONTINUOUS	B4	1.0	40

FULL LOAD EFF:	82	3/4 LOAD EFF:	75.2	1/2 LOAD EFF:	69	GTD. EFF		ELEC. TYPE	
FULL LOAD PF:	86	3/4 LOAD PF:	79.4	1/2 LOAD PF:	70.3	78.5	CAP START CAP RUN		

F.L. TORQUE	LOCKED ROTOR AMPS	L.R. TORQUE	B.D. TORQUE	F.L. RISE°C
5.99 LB-FT	133 / 66.5	16.2 LB-FT 271 %	15.4 LB-FT 258 %	96.9

SOUND PRESSURE @ 3 FT.	SOUND POWER	ROTOR WK^2	MAX. WK^2	SAFE STALL TIME	STARTS / HOUR	APPROX. MOTOR WGT
56 dBA	66 dBA	0.15 LB-FT^2	0 LB-FT^2	10 SEC.	0	46 LBS.

***** SUPPLEMENTAL INFORMATION *****

DE BRACKET TYPE	ODE BRACKET TYPE	MOUNT TYPE	ORIENTATION	SEVERE DUTY	HAZARDOUS LOCATION	DRIP COVER	SCREENS	PAINT
C-FACE	STANDARD	RIGID	HORIZONTAL	FALSE	NONE	FALSE	NONE	BLUE - LEESON (ENAMEL)

BEARINGS		GREASE	SHAFT TYPE	SPECIAL DE	SPECIAL ODE	SHAFT MATERIAL	FRAME MATERIAL
DE	ODE						
BALL	BALL	POLYREX EM	T	NONE	NONE	1144 STRESSPROOF (C-223)	ROLLED STEEL
6205	6203						

THERMO-PROTECTORS				THERMISTORS	CONTROL	SPACE HEATERS
THERMOSTATS	PROTECTORS	WDG RTDs	BRG RTDs			
NONE	MANUAL	NONE	NONE	NONE	FALSE	NONE VOLTS

*
N
O
T
E
S

INVERTER TORQUE: NONE
INV. HP SPEED RANGE: NONE
ENCODER: NONE
NONE NONE
NONE NONE PPR
BRAKE: NONE NONE
NONE P/N NONE
NONE NONE
NONE FT-LB NONE V NONE HZ

